

## **Kogan SmarterHome™ Inverter Split System Air Conditioner**

**2.6kW, 3.5kW, 5.2kW, 7.0kW (Reverse Cycle)**

KASSAC26TA, KASSAC35TA, KASHSAC52TA & KASHSAC70TA

Safety & Warnings	3
Overview	6
Installation	11
Connect to the SmarterHome™ App	32
Google Home	35
Alexa	38
Operation	42
Cleaning & Care	51
Troubleshooting	60
Notes	62

# Safety & Warnings

- Read this guide before installing and using the appliance.
- During installation of the indoor and outdoor units, children must be kept away from the working area. Unforeseeable accidents could occur.
- Ensure that the base of the outdoor unit is firmly secured.
- When moving the air conditioner, ensure that air cannot enter the refrigerant system and check for refrigerant leaks.
- Perform a test cycle after installation and record the operating data.
- Protect the indoor unit with a fuse of suitable capacity for the maximum input current or use another appropriate overload protection device.
- Ensure that the electrical voltage matches the rating plate. Keep the switch or power plug clean. Insert the plug firmly into the outlet to avoid the risk of electric shock or fire due to poor contact.
- Ensure the electrical outlet is suitable for the plug. If not, have the outlet replaced.
- The appliance must be fitted with a means of disconnection from the power supply, with a contact separation in all poles that provides full disconnection under overvoltage category III conditions. This must be incorporated into the fixed wiring in accordance with applicable wiring rules.
- The air conditioner must be installed by a licensed trade professional.
- Do not install the appliance less than 50cm from flammable substances (e.g. alcohol) or pressurised containers (e.g. spray cans).
- If used in areas without ventilation, take precautions to prevent refrigerant gas from accumulating and creating a fire hazard.
- Packaging materials are recyclable and should be disposed of in appropriate recycling bins. Take the air conditioner to a waste collection centre at the end of its service life.
- Only operate the air conditioner as described in this user guide. These instructions do not cover all possible conditions or situations. As with any electrical appliance, use common sense and caution during installation, operation, and maintenance.
- The appliance must be installed in accordance with national regulations.
- Disconnect all power circuits before accessing the terminals.
- This appliance can be used by children aged 8 and above and by persons with reduced physical, sensory, or mental capabilities, or lack of experience and knowledge, if supervised or instructed on its safe use and they understand the hazards involved.
- Children must not play with the appliance.
- Cleaning and maintenance must not be performed by children without supervision.

- Do not attempt to install the air conditioner yourself. Always contact a qualified trade professional.
- Maintenance must be carried out by a qualified trade professional. Always disconnect the appliance from the power supply before performing any maintenance.
- Do not unplug the appliance while it is operating. This could create a spark and cause a fire.
- This appliance is intended for air conditioning domestic environments only. Do not use it for other purposes such as drying clothes or cooling food.
- Always use the appliance with the air filter installed. Operating without the filter can cause dust or debris buildup and may lead to failure.
- The user is responsible for ensuring installation is carried out by a licensed trade professional. Proper grounding must be verified, and a thermomagnetic circuit breaker must be installed.
- Recycle or dispose of the remote control batteries properly. Use designated collection points for battery disposal.
- Avoid prolonged direct exposure to the cold air flow. It may be harmful to health, especially for children, elderly people, or those who are ill.
- If the appliance emits smoke or a burning smell, immediately cut the power supply and contact a qualified trade professional. Continued use could result in fire or electric shock.
- Repairs must only be performed by a qualified trade professional. Incorrect repairs can pose risks of electric shock or other hazards.
- Adjust the airflow direction correctly. Point the air deflector downwards in 'Heating' mode and upwards in 'Cooling' mode.
- Disconnect the appliance from the power supply if it will be unused for an extended period or before cleaning or maintenance.
- Selecting an appropriate temperature setting can help prevent damage to the appliance.
- Do not bend, pull, or compress the power cord. A damaged cord can cause electric shock or fire. Only a qualified trade professional may replace the power cord.
- Do not use extension cords or power boards with this appliance.
- Do not touch the appliance with wet hands or when barefoot.
- Do not block the air inlet or outlet of either the indoor or outdoor unit. Obstruction can reduce efficiency and cause damage.
- Do not modify the appliance.
- Do not install the appliance in environments with gas, oil, sulphur, or near heat sources.

- This appliance is not intended for use by individuals (including children) with reduced physical, sensory, or mental capabilities, or lack of experience and knowledge, unless properly supervised or instructed.
- Do not climb on or place heavy or hot objects on the appliance.
- Do not leave doors or windows open for extended periods while the air conditioner is operating.
- Do not direct airflow at plants or animals. Prolonged exposure to cold air can harm them.
- Do not expose the appliance to water. Damaged insulation can lead to electric shock.
- Do not climb on or place objects on the outdoor unit.
- Never insert sticks or similar objects into the appliance, as this may cause injury.
- Children should be supervised to ensure they do not play with the appliance.



**Caution:** Risk of fire



Operating instructions



Read the user guide

# Overview

## Indoor Unit – Box 1

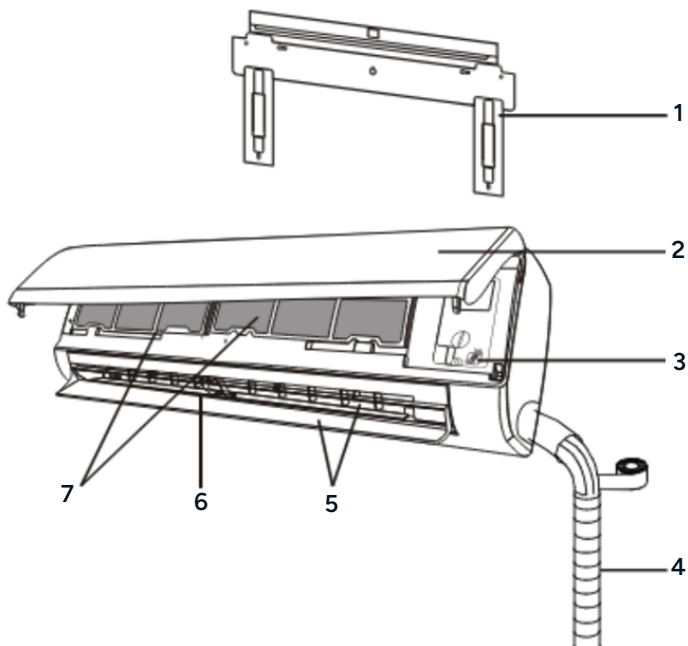

- 1 Mounting Plate
- 2 Front Panel
- 3 Emergency Button
- 4 Refrigerant Connecting Pipe
- 5 Air Deflector and Flap
- 6 Air Outlet
- 7 Air Filter

## Outdoor Unit (With the Protective Cover Removed) – Box 2

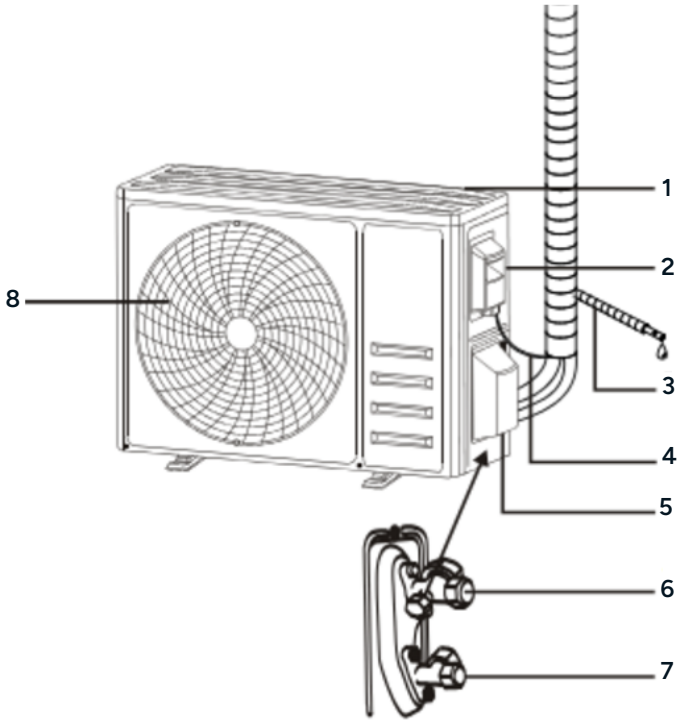

- 1 Air Inlet
- 2 Wiring Cover
- 3 Drainage Pipe
- 4 Connection Wiring
- 5 Valve Protective Cover
- 6 Gas Valve (Low Pressure Valve)
- 7 Liquid Valve (High Pressure Valve)
- 8 Air Outlet

**Note:**

This figure may differ from the actual appliance. Refer to the actual appliance as the standard.

## Indoor Unit Display Screen

























1	Time Display	This display shows the timer settings, current temperature, and error codes.
2	Timer Indicator	This indicator illuminates when the timer is active.
3	Sleep Indicator	This symbol appears when 'SLEEP' mode is activated.
4	Operation Indicator	This indicator illuminates when the unit is in operation.
5	Power Indicator	This symbol lights up when the air conditioner is powered on and turns off when the unit is off.

## Remote Control





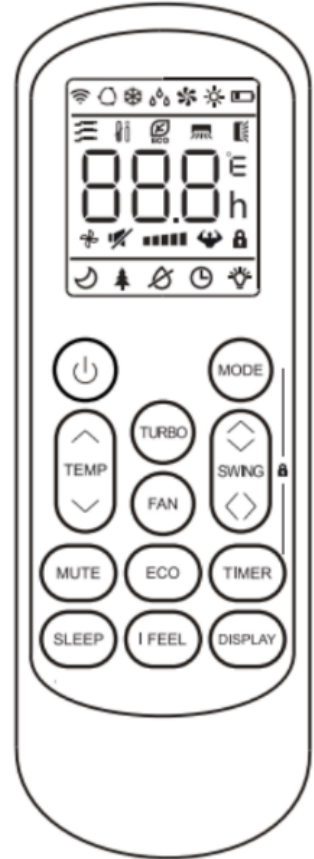

- The display and some functions of the remote control may vary according to the model.
- The shape and position of the buttons and indicators may vary according to the model, but their function is the same.
- The unit confirms the correct reception of each button with a beep.

## Display Screen

Symbol	Meaning
	Battery Indicator
	Auto Mode
	Cooling Mode
	Dry Mode
	Fan Only Mode
	Heating Mode
	ECO Mode
	Timer
	Temperature Indicator
	Fan Speed: Auto/Low/Low-mid/Mid/Mid-High/High
	Mute Function
	Turbo Function
	Up-down Auto Swing
	Left-right Auto Swing
	Sleep Function
	Health Function
	I Feel Function
	Signal Indicator
	Gentle Air
	Child Lock
	Display On/Off
	Anti-mildew



## Buttons

Button	Function
	Press to turn the air conditioner on or off.
	Press to increase the temperature or timer setting.
	Press to decrease the temperature or timer setting.
MODE	Press to select the mode of operation: 'Auto', 'Cooling', 'Drying', 'Fan', or 'Heating'.
ECO	Press to activate or deactivate the 'ECO' function.
	Press and hold to activate or deactivate the '8°C Heating' function (depending on the model).
TURBO	Press to activate or deactivate the 'Turbo' function.
FAN	Press to select the fan speed: 'Auto', 'Low', 'Mid', or 'High'.
TIMER	Press to set the timer and turn the timer on or off.
SLEEP	Press to turn the 'Sleep' function on or off.
DISPLAY	Press to turn the indoor unit display screen on or off.
SWING 	Press to stop or start the horizontal air deflector movement or sets the desired up/down airflow direction.
SWING 	Press to stop or start the vertical air deflector movement or set the desired left/right airflow direction.
I FEEL	Press to turn the 'I Feel' function on or off.
MUTE	Press to turn the 'Mute' function on or off.
	Press and hold to activate or deactivate the 'Gen' function (depending on the model).
MODE + TIMER	Press to activate or deactivate the 'Child-lock' function.
SWING  SWING 	Press to activate or deactivate the 'Self-clean' function (depending on the model).
FAN + MUTE	Press to activate or deactivate the 'Gentle Air' function (depending on the model).
SLEEP + DISPLAY	Press to activate or deactivate the 'Health' function (depending on the model).

# Installation

## Note:

This air conditioner must be installed by a licensed trade professional.

## Important Considerations

- When filling the combustible refrigerant, incorrect operation may cause serious injury or damage to the appliance.
- A leak test must be done after installation is completed.
- A safety inspection must be conducted before performing maintenance or repairs on an air conditioner using combustible refrigerant to ensure that the fire risk is reduced to minimum.
- It is necessary to operate the air conditioner according to established safety protocols to ensure that any risk arising from combustible gas or vapor during operation is minimised.
- Requirements for the total weight of filled refrigerant and the area of a room to be equipped with an air conditioner are shown in the following Tables GG.1 and GG.2.

## Maximum Charge and the Required Minimum Floor Area

- $m_1 = (4 \text{ m}^3) \times \text{LFL}$ ,  $m_2 = (26 \text{ m}^3) \times \text{LFL}$ ,  $m^3 = (130 \text{ m}^3) \times \text{LFL}$ .
- Where LFL is the lower flammable limit in  $\text{kg}/\text{m}^3$ , R32 LFL is  $0.306 \text{ kg}/\text{m}^3$ .

## Appliances with a Charge Amount $m_1 < M = m_2$ :

- The maximum charge in a room must be in accordance with the following:  $m_{\text{max}} = 2.5 \times (\text{LFL})^{(5/4)} \times h_0 \times (A)^{1/2}$ .
- The required minimum floor area to install an appliance with refrigerant charge  $M$  (kg) shall be in accordance with following:  $A_{\text{min}} = (M / (2.5 \times (\text{LFL})^{(5/4)} \times h_0))^2$ .

**Table GG.1 - Maximum Charge (kg)**

Category	LFL (kg/m <sup>3</sup> )	h <sub>0</sub> (m)	Floor area (m <sup>2</sup> )						
			4	7	10	15	20	30	50
R32	0.306	1	1.14	1.51	1.8	2.2	2.54	3.12	4.02
		1.8	2.05	2.71	3.24	3.97	4.85	5.61	7.254
		2.2	2.5	3.31	3.96	4.85	5.6	6.68	8.85

**Table GG.2 – Minimum Room Area (m<sup>2</sup>)**

Category	LFL (kg/m <sup>3</sup> )	h <sub>0</sub> (m)	Charge amount (M) (kg) minimum room area (m <sup>2</sup> )						
			1.224 kg	1.386 kg	2.448 kg	3.672 kg	4.896 kg	6.12 kg	7.956 kg
R32	0.306	0.6		29	51	116	206	321	543
		1		10	19	42	74	116	196
		1.8		3	6	13	23	36	60
		2.2		2	4	9	15	24	40

## Installation Safety Principles

### Site Safety

- Open flames are prohibited in the installation area.
- Adequate ventilation must be ensured during installation.

### Operation Safety

- Be cautious of static electricity during operation.
- Protective clothing and antistatic gloves must be worn while handling components.
- Do not use a mobile phone during installation or operation.

## Installation Safety

- A refrigerant leak detector must be used during installation.
- The installation location must be appropriate and comply with safety requirements.
- The installation site must be well-ventilated.
- For air conditioners using refrigerant R32, the installation and maintenance site must be free from open flames, welding, smoking, or any heat source exceeding 548°C, which may easily produce an open flame.
- When installing an air conditioner, appropriate anti-static measures must be taken, such as wearing anti-static clothing and/or gloves.
- The site must be convenient for installation and maintenance. The air inlets and outlets of both indoor and outdoor units must not be obstructed, nor should they be located near heat sources or in combustible or explosive environments.
- If a refrigerant leak occurs from the indoor unit during installation, immediately turn off the valve of the outdoor unit and evacuate all personnel. Allow at least 15 minutes for the refrigerant to completely dissipate. If the product is damaged, cease use immediately and contact **help.Kogan.com** for support. Welding refrigerant pipes or performing similar operations on-site is strictly prohibited.
- The location selected must allow the air intake and outlet of the indoor unit to be unobstructed and evenly distributed.
- Avoid installing the unit in locations where electrical products, power switches, plugs, outlets, kitchen cabinets, beds, sofas, or other valuables are located directly below the unit or its piping.

## Recommended Tools



Standard Spanner



Vacuum Pump



Phillips Head Screwdriver



Flat Head Screwdriver



Torque Wrench



Work Gloves



Spirit Level



Drill & Drill Bits



Micron Gauge



Clamp on Amp Meter



Pipe Cutter



Adjustable/  
Crescent  
Wrench



Safety Glasses



Manifold and  
Gauges



Allen Key



Refrigerant  
Scale



Flaring Tool



Hole Saw

## Pipe Length and Additional Refrigerant

Inverter models capacity (Btu/h)	9K-12K		18K-24K		30K-36K	
Length of pipe with standard charge	5m/ 16ft	5m/ 16ft	5m/ 16ft	5m/ 16ft	5m/ 16ft	5m/ 16ft
Length of pipe with standard charge (North American, etc.)	7.5m/ 24ft	7.5m/ 24ft	7.5m/ 24ft	7.5m/ 24ft	7.5m/ 24ft	7.5m/ 24ft
Maximum distance between indoor and outdoor unit	15m/ 49ft	15m/ 49ft	20m/ 65ft	20m/ 65ft	30m/ 98ft	30m/ 98ft
Additional refrigerant charge	20g/ m	15g/m	30g/ m	25g/m	30g/m	25g/ m
Max. diff. in level between indoor and outdoor unit	10m/ 32ft	10m/ 32ft	15m/ 48ft	15m/ 48ft	20m/ 65ft	20m/ 65ft
Type of refrigerant	R22/ R410 A	R32	R22/ R410 A	R32	R22/ R410 A	R32

ON-OFF models' capacity (Btu/h)	9K-12K		18K-36K	
Length of pipe with standard charge	5m/16ft	5m/16ft	5m/16ft	5m/16ft
Maximum distance between indoor and outdoor unit	15m/49ft	15m/49ft	15m/49ft	15m/49ft
Additional refrigerant charge	20g/m	15g/m	30g/m	25g/m
Max. diff. in level between indoor and outdoor unit	5m/16ft	5m/16ft	5m/16ft	5m/16ft
Type of refrigerant	R22/R410A	R32	R22/R410A	R32

## Torque Parameters

Pipe size	Newton meter (N x m)	Pound-force foot (lbs-ft)	Kilogram-force meter (kgs-m)
1/4 (ø6.35)	15-20	11.1 – 14.8	1.5-2.0
3/8 (ø9.52)	31-35	22.9-25.8	3.2-3.6
1/2 (ø12)	45-50	33.2-36.9	4.6-5.1
5/8 (ø15.88)	60-65	44.3-48.0	6.1-6.6

## Dedicated Distribution Device and Wire for Air Conditioner

Min. circuit ampacity of air conditioner (A)	Minimum Wire Cross-sectional Area (mm <sup>2</sup> )	Specification of socket or switch (A)	Fuse specification (A)
≤8	0.75	15	15
>8 and ≤10	1.0	15	15
>10 and ≤15	1.5	20	25
>15 and ≤24	2.5	25	40
>24 and ≤28	4.0	35	45
>28 and ≤32	6.0	40	55

### Note:

This table is only for reference. The installation must meet the requirements of local laws and regulations.

## Indoor Unit Installation

### Step 1: Select the Installation Location

- Ensure the installation complies with the minimum installation dimensions (defined below) and meets the minimum and maximum connecting pipe lengths and the maximum change in elevation as specified in the 'Installation' section.
- Air inlets and outlets must be free of obstructions to ensure proper airflow throughout the room.
- The location must allow for safe and easy drainage of condensation.
- All connections to the outdoor unit must be easily accessible.
- The indoor unit must be installed out of reach of children.
- The mounting wall must be strong enough to withstand 4 times the full weight and vibration of the unit.
- The air filter must be easily accessible for routine cleaning.
- Allow sufficient free space for access to routine maintenance tasks.
- Install the unit at least 3m away from TV or radio antennas. Operation of the air conditioner may interfere with reception in areas where the signal is weak. An amplifier may be required for the affected device.
- Do not install the unit in a laundry room or near a swimming pool due to the risk of corrosion from the humid environment.
- For ETL-certified areas: **Caution:** Mount the unit with the lowest moving parts at least 2.4m above the floor.

### Minimum Installation Dimensions:

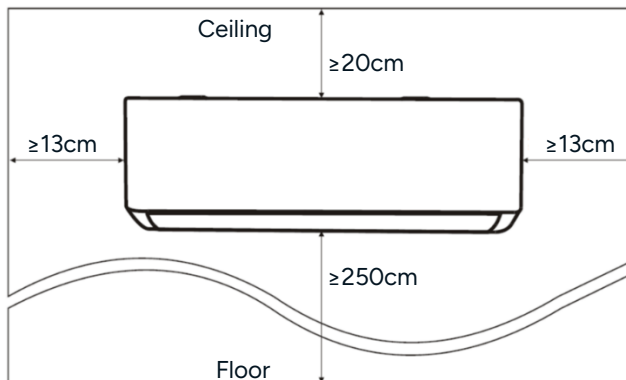

## Step 2: Install the Mounting Plate

1. Take the mounting plate from the rear of the indoor unit.
2. Ensure you meet the minimum installation dimension requirements as described in step 1. Based on the size of the mounting plate, determine the position and stick the mounting plate close to the wall.
3. Adjust the mounting plate to a horizontal position using a spirit level, then mark the screw hole positions on the wall.
4. Remove the mounting plate and drill holes at the marked positions with a drill.
5. Insert wall anchors into the holes, then hang the mounting plate and secure it with screws.

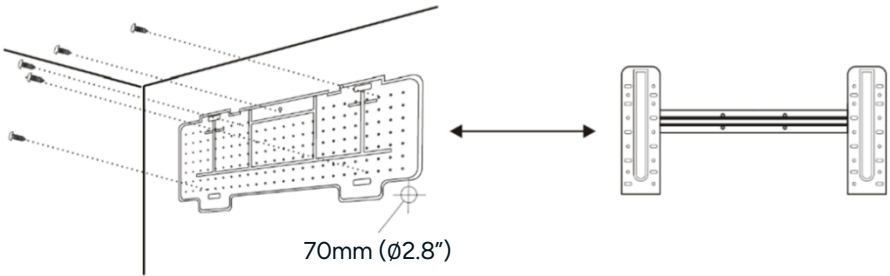

### Notes:

- Ensure the mounting plate is firm enough and flat against the wall after installation.
- The figure shown may differ from the actual appliance. Refer to the actual appliance as the standard.

### Step 3: Drill the Wall Hole

A hole in the wall should be drilled for refrigerant piping, the drainage pipe and connecting cables.

1. Determine the location of the wall hole based on the position of the mounting plate.
2. The hole should have a diameter of at least 70mm and a slight oblique angle to facilitate drainage.
3. Drill the wall hole using a 70mm core drill, maintaining a slight oblique angle, with the indoor end being about 5mm to 10mm lower.
4. Place the wall sleeve and wall sleeve cover (both are optional) to protect the connection points.

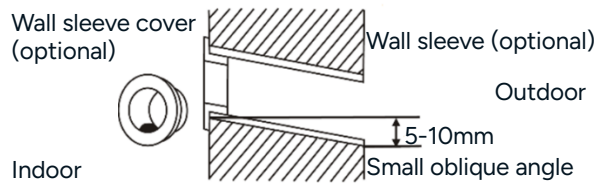
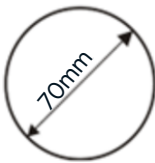

#### Note:

Take care to avoid electrical wiring, plumbing, and other sensitive components when drilling the wall hole.

#### Step 4: Connecting the Refrigerant Pipe

1. Based on the wall hole position, select the appropriate piping method. There are 3 optional piping methods for indoor units, as shown in the figure below. In Piping Method 1 or Piping Method 3, a notch should be made by using scissors to cut the plastic sheet of the piping outlet and cable outlet on the corresponding side of the indoor unit.

#### Note:

When cutting off the plastic sheet at the outlet, ensure the cut is trimmed smoothly.

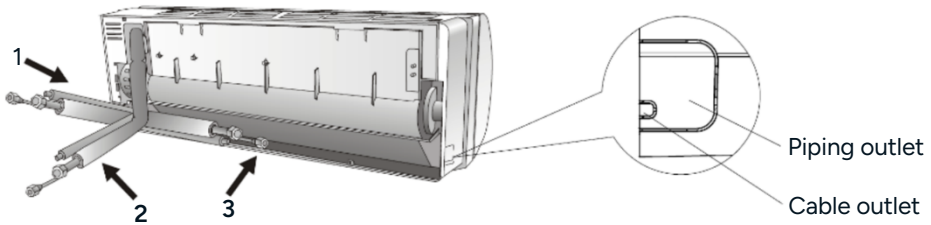

2. Bend the connecting pipes with the port facing up, as shown in the figure below.

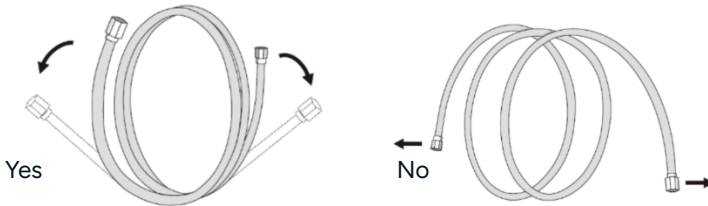

3. Remove the plastic cover from the pipe ports and the protective cover from the end of the piping connectors.
4. Check whether there is any debris on the port of the connecting pipe and ensure the port is clean.
5. After aligning the centre, rotate the nut of the connecting pipe to tighten it as much as possible by hand.
6. Use a torque wrench to tighten it according to the torque values in the 'Torque Parameters' table in the 'Installation' section.

7. Wrap the joint with the insulation pipe.

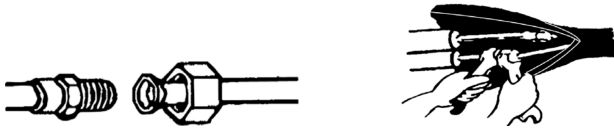

**Note:**

For R32 refrigerant, the connector should be placed outdoors.

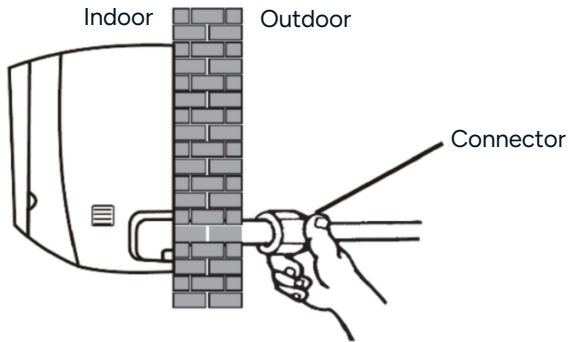

### Step 5: Connect Drainage Hose

1. Adjust the drainage hose (if applicable). In some models, both sides of the indoor unit are provided with drainage ports. You can choose one of them to attach the drainage hose and plug the unused drainage port with the rubber attached in one of the ports.

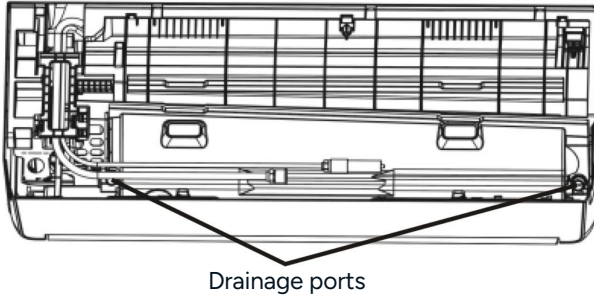

2. Connect the drainage hose to the drainage port, ensuring the joint is firm and the sealing effect is strong.
3. Wrap the joint firmly with Teflon tape to ensure no leaks.

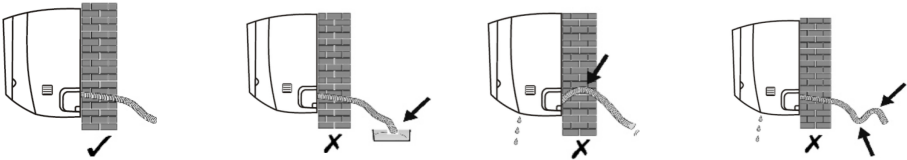

#### Note:

Ensure the pipes are free from twists or dents and are positioned with a downward slope to prevent blockages and ensure proper drainage.

## Step 6: Connect Wiring

1. Choose the appropriate cable size based on the maximum operating current indicated on the nameplate (refer to the 'Installation' section).
2. Open the front panel of the indoor unit.
3. Use a screwdriver to open the control box cover and reveal the terminal block.
4. Unscrew the cable clamp.
5. Insert one end of the cable into the control box position from the back of the right end of the indoor unit.
6. Connect the wires to the corresponding terminals according to the wiring diagram on the electric control box cover, ensuring they are securely connected.
7. Screw the cable clamp to fasten the cables.
8. Reinstall the electric control box cover and front panel.

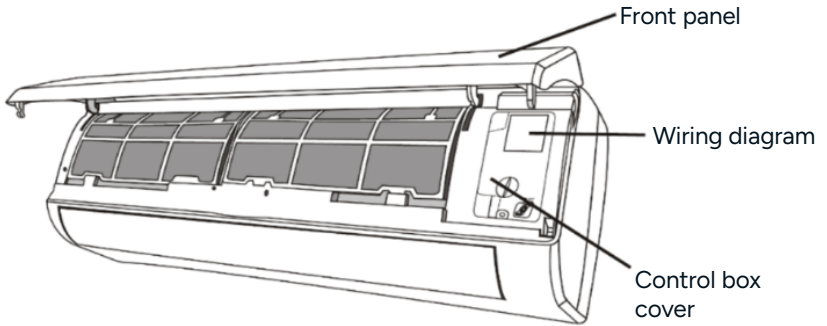

## Step 7: Wrap Piping and Cable

After the refrigerant pipes, connecting wires and drainage hose are all installed, they must be bundled with insulating tape before passing them through the wall hole. This will save space, protect and insulate them.

1. Arrange the pipes, cables and drainage hose as shown in the following figure.

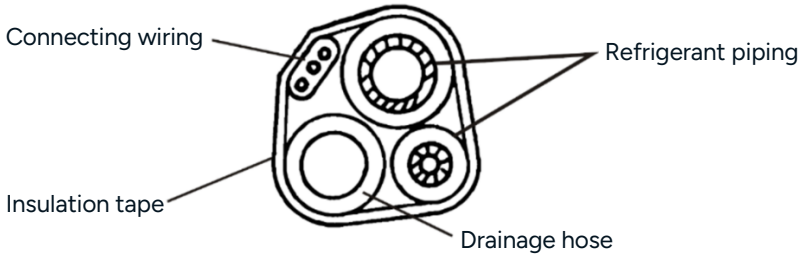

### Notes:

- Ensure the drainage hose is at the bottom.
  - Avoid crossing and bending the hose.
2. Wrap the refrigerant pipes, connecting wires and drainage hose tightly together using insulating tape.

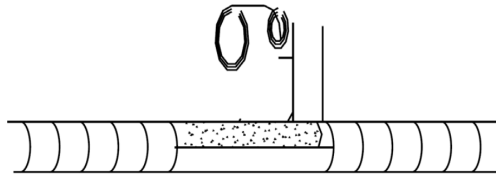

### **Step 8: Mount the Indoor Unit**

- 1.** Slowly pass the bundled refrigerant pipes, connecting wires and drainage hose through the wall hole.
- 2.** Hook the top of the indoor unit onto the mounting plate.
- 3.** Apply slight pressure to the left and right sides of the indoor unit to ensure it is hooked firmly.
- 4.** Push down the bottom of the indoor unit to secure the snaps onto the hooks of the mounting plate, ensuring it is hooked firmly.
- 5.** If the refrigerant pipes were already embedded in the wall or if you want to connect the pipes and wires on the wall, follow these steps:
  - a.** Hook the top of the indoor unit onto the mounting plate without piping and wiring.
  - b.** Lift the indoor unit away from the wall, unfold the bracket on the mounting plate and use this bracket to prop up the indoor unit, creating a larger space for operation.
  - c.** Complete the refrigerant piping, wiring and drainage hose connection, then wrap them as described in Steps 4 to 7.

## Outdoor Unit Installation

### Note:

Remove the paperboard from the outdoor unit before installation.

### Step 1: Select the Installation Location

- Do not install the outdoor unit near sources of heat, steam or flammable gas.
- Do not install the unit in windy or dusty places.
- Do not install the unit where people often pass. Select a place where the air discharge and operating sound will not disturb the neighbours.
- Avoid installing the unit where it will be exposed to direct sunlight (otherwise use a protection, if necessary, that will not interfere with the air flow).
- Reserve the spaces as shown in the figure below for the air to circulate freely.
- Install the outdoor unit in a safe and solid place.
- If the unit is subject to vibration, place rubber covers onto the feet of the unit.

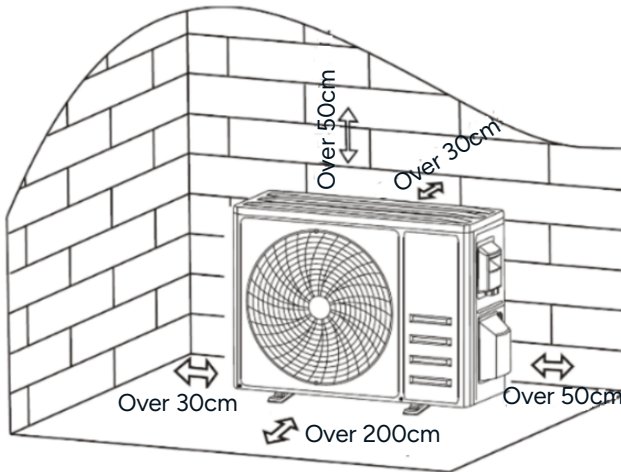

### Step 2: Install the Drainage Hose

1. This step applies only to heat pump models or RCACs.
2. Insert the drainage joint into the hole at the bottom of the outdoor unit.
3. Connect the drainage hose securely to the joint, ensuring a proper and tight connection.

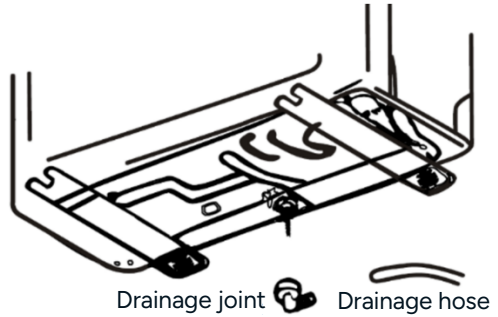

### Step 3: Mounting the Outdoor Unit

1. Mark the installation position for the expansion bolts according to the outdoor unit installation dimensions.
2. Drill holes, clean out the concrete dust and insert the bolts.
3. If applicable, install 4 rubber covers over the feet before placing the outdoor unit. This will reduce vibrations and noise.
4. Position the outdoor unit base over the bolts and pre-drilled holes.
5. Use a spanner to firmly secure the outdoor unit with the bolts.

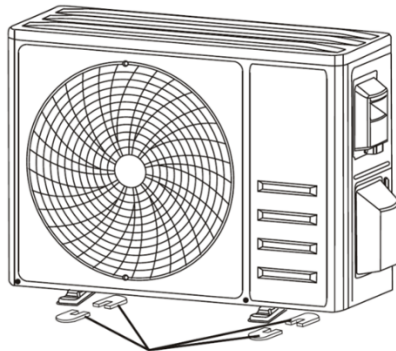

Install 4 rubber covers (optional)

#### Note:

The outdoor unit can be mounted on a wall bracket. Follow the instructions for the wall bracket to securely attach it to the wall, then fasten the outdoor unit to the bracket, ensuring it is level. The wall bracket must be able to support at least 4 times the weight of the outdoor unit.

#### Step 4: Install Wiring

1. Use a Phillips head screwdriver to unscrew the wiring cover, then gently grasp and press it down to remove it.
2. Unscrew the cable clamp and remove it.
3. According to the wiring diagram inside the wiring cover, connect the wires to the corresponding terminals and ensure all connections are firm and secure.
4. Reinstall the cable clamp and wiring cover.

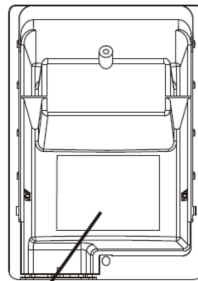
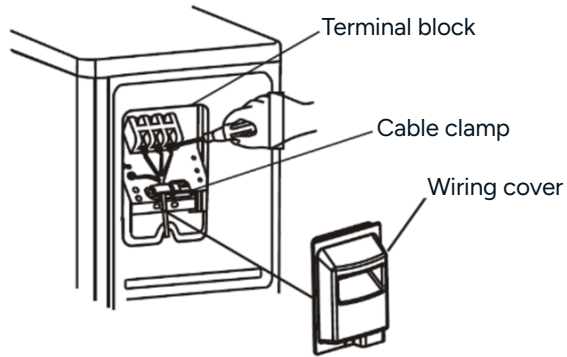

Wiring diagram

#### Note:

When connecting the wires of indoor and outdoor units, the power must be cut off.

## Step 5: Connect the Refrigerant Pipe

1. Unscrew the valve cover, then gently grasp and press it down to remove it (if applicable).
2. Remove the protective caps from the ends of the valves.
3. Remove the plastic cover from the pipe ports, check for any debris on the port of the connecting pipe and ensure the port is clean.
4. Align the centre, then rotate the flare nut of the connecting pipe and tighten it by hand as much as possible.
5. Use a spanner to hold the valve body and a torque wrench to tighten the flare nut according to the torque values in the torque requirements table (refer to the 'Torque Parameters' table in the 'Installation' section).

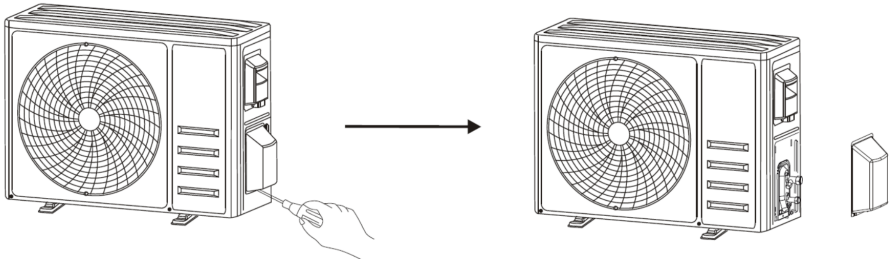

Remove the valve cover

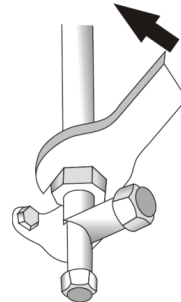
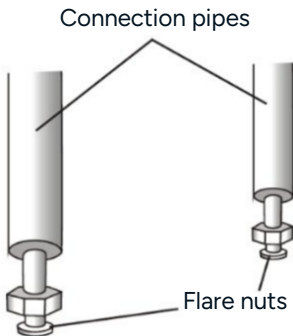

## Step 6: Vacuum Pumping

1. Use a spanner to remove the protective caps from the service port, low-pressure valve and high-pressure valve of the outdoor unit.
2. Connect the pressure hose of the manifold gauge to the service port on the outdoor unit's low-pressure valve.
3. Connect the charge hose from the manifold gauge to the vacuum pump.
4. Open the low-pressure valve of the manifold gauge and close the high-pressure valve.
5. Turn on the vacuum pump to evacuate the system.
6. The vacuum time should be at least 15 minutes or until the compound gauge indicates  $-0.1 \text{ MPa}$  ( $-76 \text{ cm Hg}$ ).
7. Close the low-pressure valve of the manifold gauge and turn off the vacuum pump.
8. Hold the pressure for 5 minutes, ensuring that the compound gauge pointer does not exceed  $0.005 \text{ MPa}$ .
9. Open the low-pressure valve anticlockwise for  $1/4$  turn with a hexagonal spanner to allow a small amount of refrigerant to fill the system. Close the low-pressure valve after 5 seconds and quickly remove the pressure hose.
10. Check all indoor and outdoor joints for leaks using soapy water or a leak detector.
11. Fully open the low-pressure valve and high-pressure valve of the outdoor unit with a hexagonal spanner.
12. Reinstall the protective caps on the service port, low-pressure valve and high-pressure valve of the outdoor unit.
13. Reinstall the valve cover.

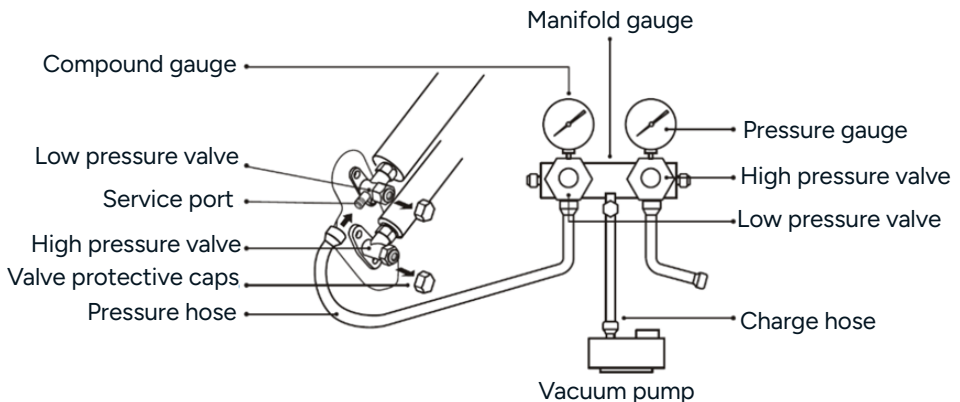

## Replacing the Remote Control Batteries

1. Remove the battery cover from the rear of the remote control by sliding it in the direction indicated by the arrow.
2. Install x2 AAA (1.5V) batteries according to the '+' and '-' directions shown on the remote control.
3. Reinstall the battery cover by sliding it back into place.

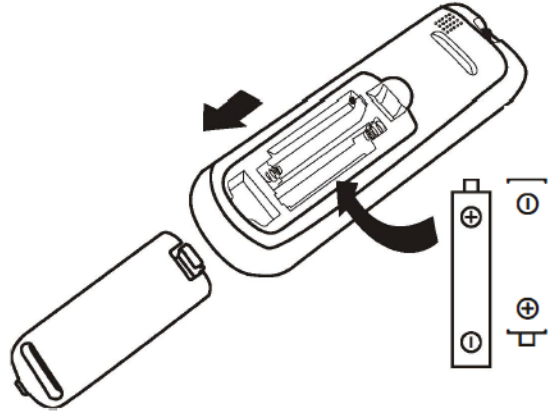

### Note:

- Do not use rechargeable batteries.
- Replace old batteries with new ones of the same type when the display becomes illegible.
- Do not dispose of batteries as unsorted municipal waste.
- Collect such waste separately for special treatment.

## Using the Remote Control

- Direct the remote control toward the air conditioner.
- Check that there are no objects between the remote control and the signal receptor in the indoor unit. Check that there are no objects between the remote control and the signal receptor in the indoor unit.
- Never leave the remote control in direct sunlight.
- Keep the remote control at a distance of at least 1m from the television or other electrical appliances.

# Connect to the SmarterHome™ App

## Install the App

Download the Kogan SmarterHome™ app from the Apple App Store (iOS) or the Google Play Store (Android).



App Store (iOS)



Play Store (Android)



## Log In or Sign Up

1. If you already have a SmarterHome account, tap 'Log In'. To register a new account, tap 'Sign Up'.
2. The app will automatically recognise your country. If needed, you can manually select your country from the drop down menu. Enter your email address, agree to the Privacy Polics and User Agreement, and tap 'Get Verification Code' to continue.
3. A 6-digit code will be sent to the submitted email address. Enter the code before the one-minute timer expires.

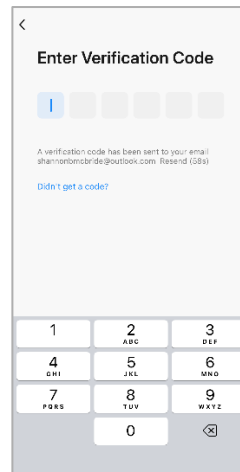
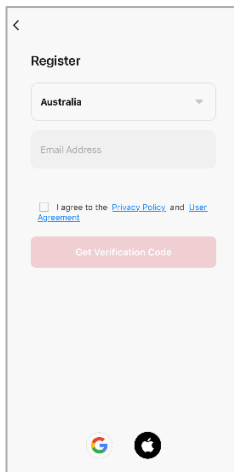
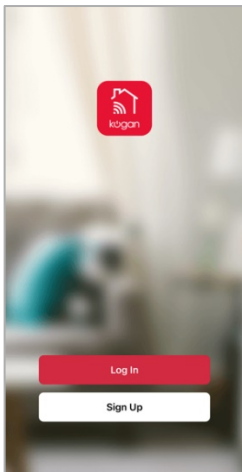

4. Enter a password that uses 6-20 characters with a mix of letters and numbers and tap 'Done'.
5. Enable the permissions and tap 'Go to App'.

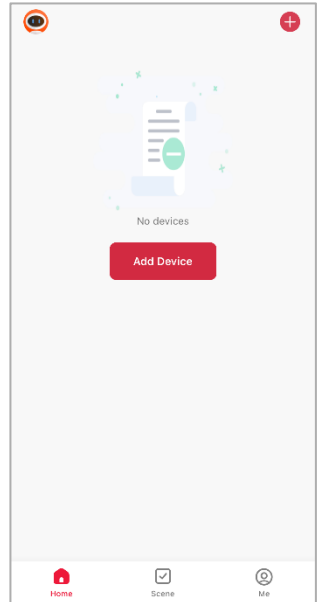
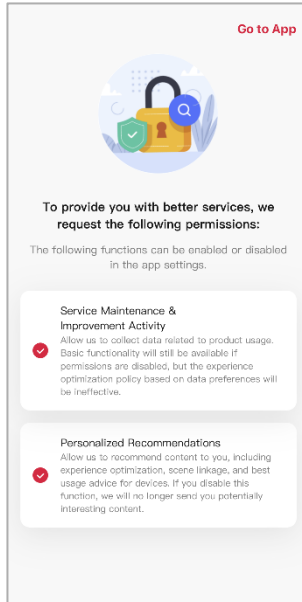
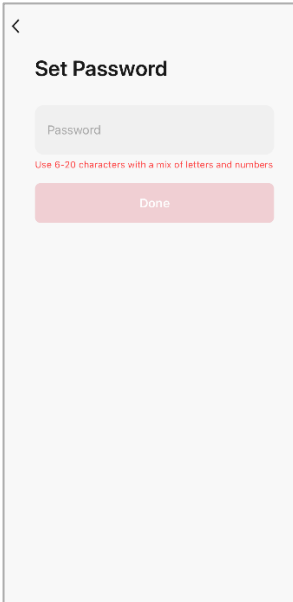

## Set the Device in Pairing Mode

When the device is first turned on, it may automatically enter pairing mode (the indoor unit display screen will beep twice, and 'AP' will illuminate on the indoor unit display).

If not automatically in pairing mode when powered on, you can manually set the device in pairing mode by pressing the 'Display' button on the remote control 6 times in 8 seconds until the indoor unit beeps twice and 'AP' illuminates on the indoor unit display screen.

## Add the Device to the App

1. Open the SmarterHome™ app.
2. Tap the '+' icon in the top right corner of the screen and select 'Add Device'.
3. Tap 'Add' when the device appears. Alternatively, select the product type from the list of options in the app (Heating and Cooling > Air Conditioners).
4. Follow the prompts to add your device to the app.

### Notes:

- The device and the app must use the same Wi-Fi network.
- The device is only compatible with 2.4Ghz networks.

## Connectivity Support

Scan the QR code below or go to <https://help.kogan.com/s/article/Kogan-SmarterHome-App-Connectivity-Support> and follow the pairing instructions for AP mode.



# Google Home

1. Ensure you are logged into the Kogan SmarterHome™ app.
2. Open the Google Home app.
3. Go to the devices tab and tap the '+ Add' button in the lower right corner.
4. Tap 'Works with Google Home'.
5. Search for 'Smarter Home' in the search bar and select 'Smarter Home' from the results.

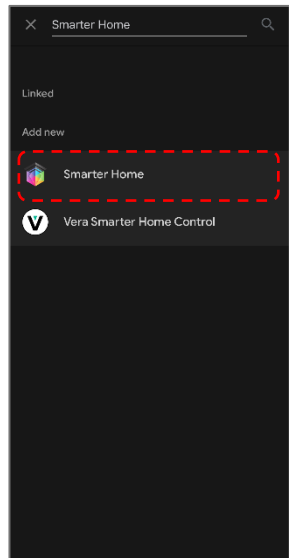
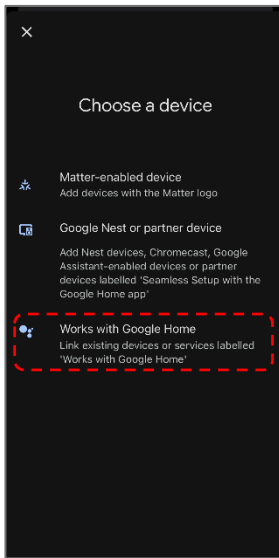
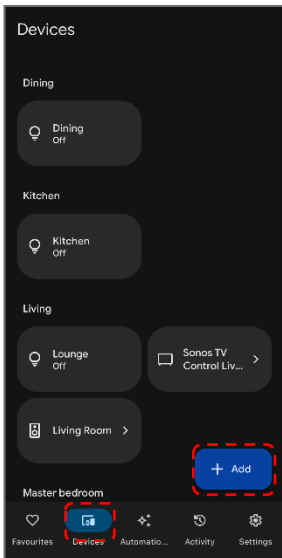

6. Tap the 'Agree and link' button.
7. Search for 'Smarter Home' in the search bar and select 'Smarter Home' from the results.
8. Once linked, a 'Smarter Home is linked' pop-up will appear at the bottom of the screen.
9. Tap your device and then tap the 'Next' button.

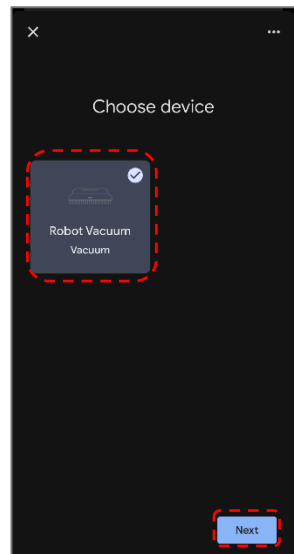
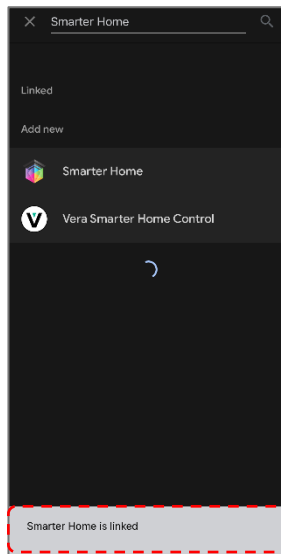
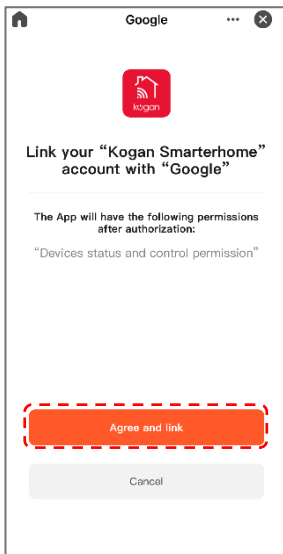

10. Select the home you wish to add the device to and tap the 'Next' button.
11. Select the room your device is in and tap the 'Next' button.

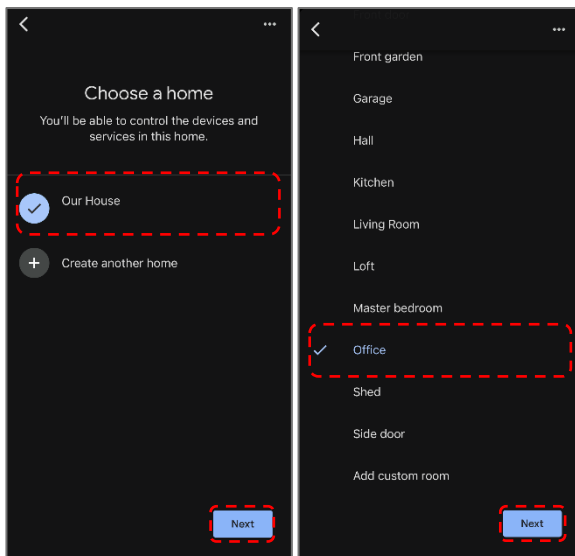

# Amazon Alexa

1. Ensure you are logged into the Kogan SmarterHome™ app.
2. Open the Amazon Alexa app.
3. Go to the 'More' tab and tap 'Skills & Games'.
4. Search for 'Smarter Home' in the search bar and select 'Smarter Home' from the results.
5. Tap the 'ENABLE TO USE' button.

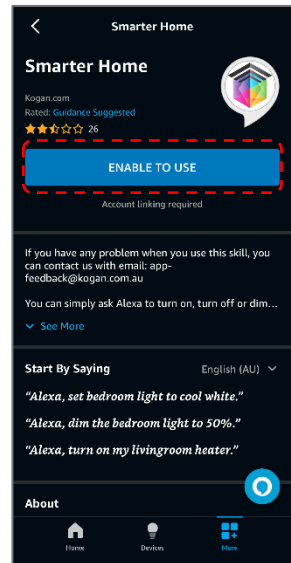
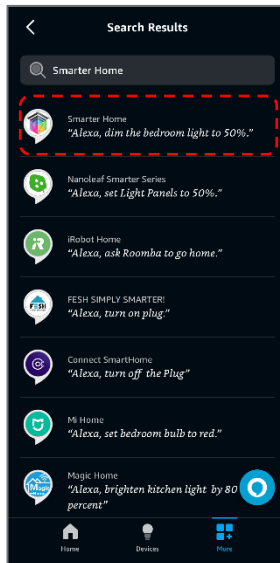
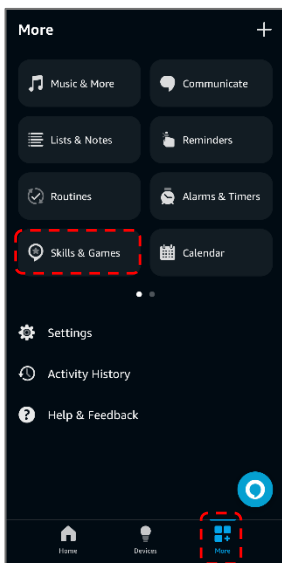

6. Tap the 'Agree and link' button.
7. Once linked, tap 'Next'. Alexa will search for any compatible devices.

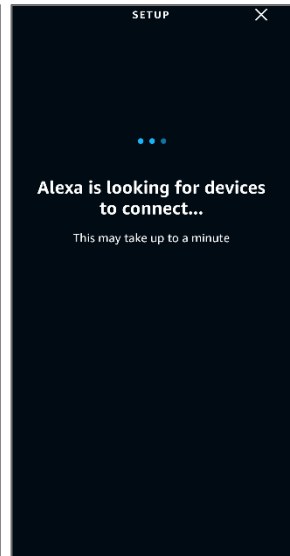
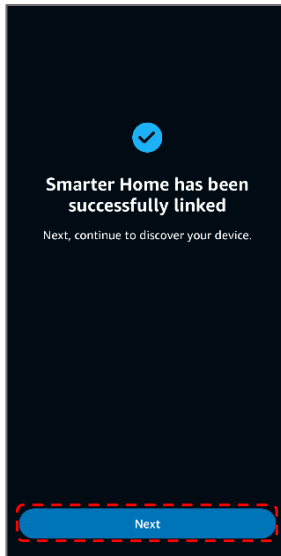
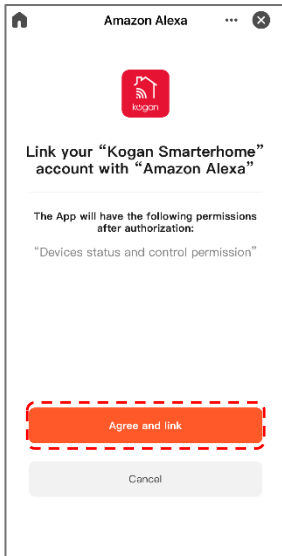

8. Once your device has been found, tap 'Next'.
9. Rename the device to your desired name and tap 'Update Name'.
10. Select the room your device is in and tap 'Add To Group'

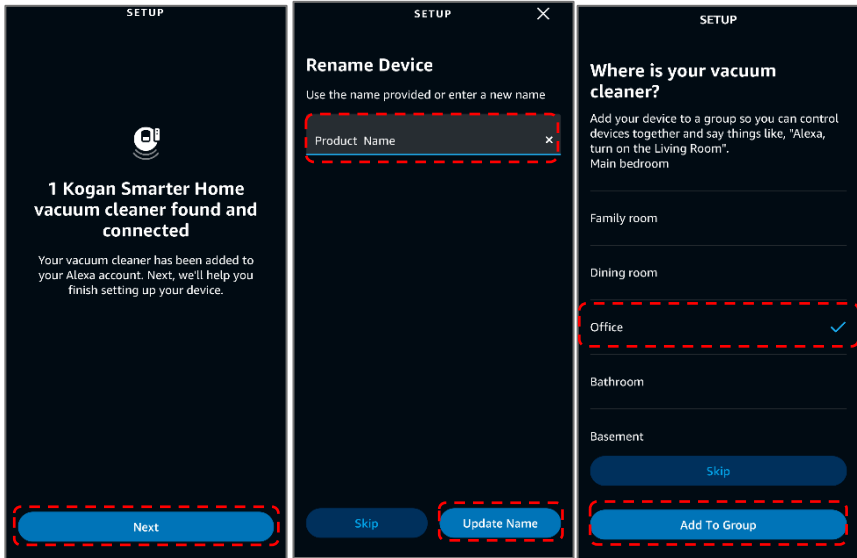

11. Once the device has been successfully added to your desired room, tap 'Continue'.
12. You can view and manage your device from the 'Devices' tab.

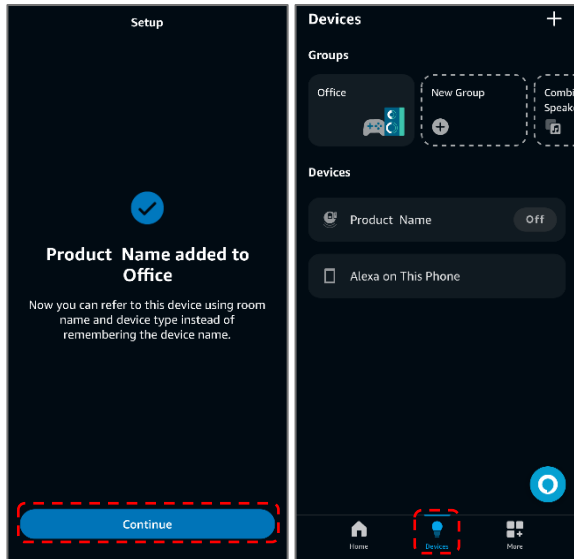

# Operation

## Cooling Mode

- The 'Cooling' function allows the air conditioner to cool the room while reducing air humidity.
- To activate the 'Cooling' function, press the 'MODE' button until the 'Cool' indicator appears on the display.
- Press the '∧' or '∨' button to set a temperature lower than that of the room.

## Fan Mode (Not Fan Button)

- The 'Fan' mode provides air ventilation only, without cooling or heating.
- To activate the 'Fan' mode, press the 'MODE' button until the 'Fan Only' indicator appears on the display.

## Dry Mode

- The 'Dry' mode reduces the humidity in the air, making the room more comfortable.
- To activate 'Dry' mode, press the 'MODE' button until the 'Dry' mode indicator appears on the display. The pre-set dehumidifying mode will activate.

## Auto Mode

- The 'Auto' mode automatically selects the appropriate operation based on the room temperature.
- To activate the 'Auto' mode, press the 'MODE' button until the 'Auto' indicator appears on the display.
- The air conditioner will automatically set the temperature and fan speed based on room conditions.

## Heating Mode

- 'Heating' mode allows the air conditioner to heat the room.
- To activate 'Heating' mode, press the 'MODE' button until the 'Heating' mode indicator appears on the display.
- Press the '^' or 'v' button to set a temperature higher than the current room temperature.
- In 'Heating' mode, the appliance may automatically enter a defrost cycle to remove frost from the condenser. This process typically lasts 2 to 10 minutes. During defrosting, the indoor fan will stop and resume operation once the process is complete.

## Fan Speed ('FAN' Button)

- Use the 'FAN' button to change the fan speed.
- Press the 'FAN' button to cycle through fan speeds in the following order: 'AUTO' → 'MUTE' → 'LOW' → 'LOW-MID' → 'MID' → 'MID-HIGH' → 'HIGH' → 'TURBO'.

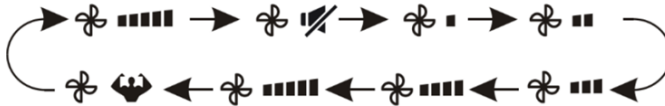

## Child Lock

- Press and hold the 'MODE' and 'TIMER' buttons simultaneously to enable or disable the child lock.
- When the child lock is active, all buttons will be disabled.

## Timer

### Note:

All programming must be completed within 5 seconds, or the settings will be cancelled.

### Turn on the Air Conditioner

- Use this function to automatically switch on the appliance.
- When the unit is off, follow these steps:
  1. Press the 'TIMER' button to begin setting the switch-on time. The 'Timer' and 'Temperature' indicators will flash.
  2. Press the '∧' or '∨' button to set the desired 'TIMER ON' time. Time increases or decreases by 30-minute intervals between 0 and 10 hours, and by 1-hour intervals between 10 and 24 hours.
  3. Press the 'TIMER' button again to confirm.
  4. After setting the 'TIMER ON', select the desired mode ('Cool', 'Heat', 'Auto', 'Fan', or 'Dry') using the 'MODE' button. Then set the fan speed with the 'FAN' button and use the '∧' or '∨' button to set the desired operating temperature.
  5. To cancel the timer, press the 'TIMER' button again.

### Turn off the Air Conditioner

- Use this function to automatically switch off the appliance.
- When the unit is on, follow these steps:
  1. Ensure the appliance is on.
  2. Press the 'TIMER' button to begin setting the switch-off time.
  3. Use the '∧' or '∨' button to select the desired time.
  4. Press the 'TIMER' button again to confirm.
  5. To cancel the timer, press the 'TIMER' button.

## Swing Function

- Use the 'SWING' buttons to adjust airflow direction.
- 1. Press 'SWING ▲/▼' to activate the horizontal deflectors for up/down movement. The 'Up Down Auto Swing' indicator will appear on the remote display. Press again to stop movement at the current angle.
- 2. Press 'SWING ◀/▶' to activate the vertical deflectors for left/right movement. The 'Left Right Auto Swing' indicator will appear on the display. Press again to stop movement at the current angle.
- Vertical deflectors can also be manually adjusted to direct airflow left or right.
- For some inverter heating models, pressing both 'SWING' buttons simultaneously will activate the 'Self-Clean' function.

## Warning

- Only adjust swing direction when the unit is switched off.
- Never manually force the flaps, as this can damage the internal mechanism.
- Never insert fingers, sticks, or objects into the air inlet or outlet vents, as this may result in injury or damage.

## Turbo Function

- To activate the 'Turbo' function, press the 'TURBO' button. The 'Turbo' indicator will appear on the display.
- Press the button again to cancel the function.
- In 'Cooling' or 'Heating' mode, this function enables rapid cooling or heating at maximum fan speed.

## Mute Function

1. Press the 'MUTE' button to activate the 'Mute' function. The 'Mute' indicator will appear on the display. Press again to deactivate.
2. While 'Mute' is active, the indoor unit operates at the lowest fan speed for quiet operation.
3. Pressing the 'FAN' or 'TURBO' button will cancel the 'Mute' function.

### Note:

'Mute' is not available in 'Dry' mode.

## **Sleep Function**

- This pre-set function gradually adjusts temperature for energy-saving and comfort during sleep.
- Press the 'SLEEP' button to activate. The 'Sleep' indicator appears on the display. Press again to cancel.
- After 10 hours of continuous operation in 'Sleep' mode, the air conditioner will revert to the previously set mode.

## **'I Feel' Function**

- Press the 'I FEEL' button to activate. The 'I Feel' indicator will appear on the remote.
- The remote control will measure the temperature at its location and send the data to the indoor unit for optimal comfort.
- Press again to deactivate.
- This function automatically turns off after 2 hours.

## **ECO Function**

- 'ECO' mode optimises operation to reduce energy consumption.
- Press the 'ECO' button to activate. The 'ECO' indicator appears on the display. Press again to cancel.

### **Note:**

'ECO' mode is available in both 'COOL' and 'HEAT' modes.

## **Display Function (Indoor Display)**

Press the 'DISPLAY' button to turn the indoor unit display screen on or off.

## Self-Clean Function

- To activate, turn off the indoor unit. Then, press both 'SWING' buttons at the same time while pointing the remote at the indoor unit. A beep will sound, and 'AC' will appear on the remote and the indoor unit display screen.
- This function removes accumulated dirt, bacteria, and other contaminants from the evaporator.
- The cycle runs for about 30 minutes, after which the unit will return to the previous mode.
- You may press the 'POWER' button to cancel the process. Two beeps will signal completion or cancellation.

## Warning

- It is normal to hear some noise during the process due to the expansion and contraction of plastic parts.
- Only use this function under the ambient conditions listed below to avoid triggering safety features.
- It is recommended to use this function every 3 months.

## Recommended Ambient Conditions

Indoor Unit Temperature	Temp < 30°C (86°F)
Outdoor Unit Temperature	5°C (41°F) < Temp < 30°C (86°F)

## Operating Environment

Using the air conditioner outside the recommended temperature range may trigger the protection device and prevent the unit from operating. Always use the appliance within the specified limits.

## Fixed Air Conditioner

MODE	Heating	Cooling	Dry
Temperature			
Room temperature	0°C~27°C (32°F~80°F)	17°C~32°C (63°F~90°F)	
Outdoor temperature	-7°C~24°C (19°F~75°F)	T1 climate: 15°C~43°C (59°F~109°F)	
		T3 climate: 15°C~52°C (59°F~125°F)	

## Inverter Air Conditioner:

MODE	Heating	Cooling	Dry
Temperature			
Room temperature	0°C~27°C (32°F~80°F)	17°C~32°C (63°F~90°F)	
Outdoor temperature	-15°C~24°C (5°F~75°F) (Low temperature heating: -20°C~24°C (-4°F~75°F))	T1 climate: 15°C~50°C (59°F~122°F) (Low temperature cooling: -15°C ~50°C (5°F~122°F))	
		T3 climate: 15°C~55°C (59°F~131°F)	

### Note:

With the power supply connected, if the air conditioner is restarted after shutdown or switched to another 'MODE' during operation, the protection device will activate. The compressor will resume operation after 3 minutes.

## Characteristics of Heating Operation (Applicable to Heat Pump Models)

### Preheating

When the 'Heating' function is enabled, the indoor unit will take 2 to 5 minutes to preheat before warm air is released.

### Defrosting

During heating, if the outdoor unit becomes frosted, the air conditioner will activate the automatic defrosting function. During this process, the indoor and outdoor fans stop running. Heating resumes automatically after defrosting is complete.

## Emergency Button

If the remote control fails, open the panel and locate the emergency button on the electronic control box. Always press this button with insulated material.

Status	Operation	Respond	Enter Mode
Standby.	Press the "Emergency" button once.	It beeps briefly once.	Cooling mode.
Standby (only for heat pump models).	Press the 'Emergency' button twice in 3 seconds.	It beeps briefly twice.	Heating mode.
Running.	Press the Emergency' button once.	It keeps beeping for a while.	Off.

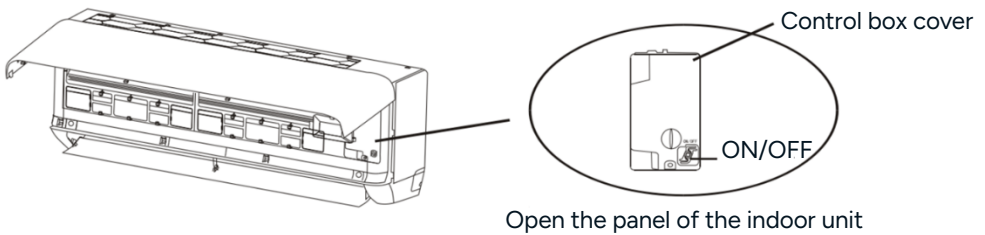

## Instructions For Servicing (R32)

- Refer to this user guide for installation dimensions and minimum spacing requirements from adjacent structures.
- The appliance must be installed, operated, and stored in a room with a floor area larger than 4 m<sup>2</sup>.
- Minimise pipework length and ensure protection from physical damage.
- Do not install pipework in unventilated spaces smaller than 4 m<sup>2</sup>.
- Comply with national gas regulations.
- Mechanical connections must remain accessible for maintenance.
- Follow instructions for handling, installing, cleaning, maintaining, and disposing of the refrigerant.

- Keep ventilation openings clear.
- **Notice:** Servicing must be carried out only as recommended by Kogan.com.
- **Warning:** Store the appliance in a well-ventilated room of appropriate size, away from open flames or ignition sources.
- The appliance must be stored to prevent mechanical damage.
- Only certified personnel, competent in handling flammable refrigerants, should perform service operations.
- All safety-related procedures must be handled by competent persons.

## **Warning**

- Do not accelerate defrosting or clean frost manually. Follow guidelines from Kogan.com.
- Store in rooms free of continuous ignition sources.
- Do not pierce or burn the appliance.
- Refrigerants may be odourless; be cautious.

# Cleaning & Care

## Warning

- When cleaning, you must shut down the machine and cut off the power supply for more than 5 minutes.
- Under no circumstances should the air conditioner be flushed with water.
- Volatile liquid (e.g. thinner or gasoline) will damage the air conditioner, so only use soft dry cloth or wet cloth dipped with neutral detergent to clean the air conditioner.
- Pay attention to cleaning the filter screen regularly to avoid dust covering which will affect the filter screen effect. When the operating environment is dusty, the cleaning frequency should be increased appropriately.
- After removing the filter screen, do not touch the fins of the indoor unit to avoid scratching.

## Cleaning

### Clean the Unit



#### Note:

Wipe frequently to keep air conditioner clean and good appearance.

## Clean the Filter

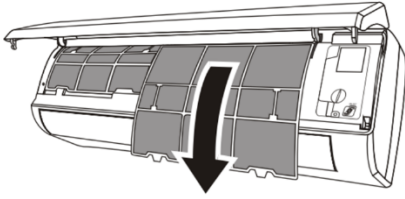

Take out the filter from the unit

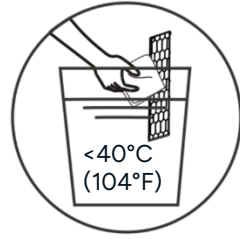

Clean the filter with soapy water and air dry it

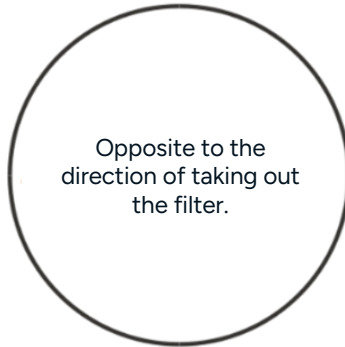

Replace the filter

### Note:

When you find accumulated dust in the filter, clean the filter promptly to ensure the clean, healthy and efficient operation inside the air conditioner.

## Maintenance

When the air conditioner is not in use for a long time, remove the batteries of the remote control and disconnect the power supply of the air conditioner. When starting to use after long-term shutdown:

1. Clean the unit and filter screen.
2. Check whether there are obstacles at the air inlet and outlet of indoor and outdoor units.
3. Check whether the drainpipe is unobstructed.
4. Install the batteries of the remote control and check whether the power is on.

# **Servicing**

## **Checks of the Area**

- Before starting work on systems containing flammable refrigerants, perform safety checks to minimise ignition risks.
- For any repairs involving the refrigerant system, the following precautions must be taken before beginning work.

## **Work Procedure**

All servicing must follow a controlled process to minimise the presence of flammable gas or vapour during the operation.

## **General Work Area**

- Maintenance staff and any individuals in the vicinity must be informed about the nature of the work.
- Avoid working in confined spaces. Clearly section off the work area.
- Ensure the environment is free from flammable materials and safe for the operation.

## **Checking for Presence of Refrigerant**

- Use an appropriate refrigerant detector before and during work to detect any flammable atmospheres.
- Leak detection equipment must be suitable for flammable refrigerants—non-sparking, sealed, or intrinsically safe.

## **Presence of Fire Extinguisher**

If hot work (e.g. brazing) is required, keep a dry powder or CO<sub>2</sub> extinguisher nearby.

## **No Ignition Sources**

- No ignition sources are permitted near refrigerant systems during repair, installation, or disposal.
- This includes open flames, smoking, and electrical sparks.
- Post visible 'No Smoking' signs in the work area.

## **Ventilated Area**

- Perform all work in an open or well-ventilated area.
- Maintain ventilation throughout the procedure to disperse any released refrigerant safely.

## **Checks to the Refrigeration Equipment**

- Ensure any electrical components replaced match the correct specification and purpose.
- Follow all service guidelines strictly. If unsure, contact **help.Kogan.com**.
- Check the following for flammable refrigerant systems:
  - The refrigerant charge size is appropriate for the room volume.
  - Ventilation systems are unobstructed and functioning.
  - If an indirect refrigeration circuit is used, inspect the secondary circuit for leaks.
  - Equipment labels and safety markings are visible and legible.
  - Refrigerant pipes and components must not be exposed to corrosive substances unless they are resistant or adequately protected.

## **Checks to Electrical Devices**

- Inspect all components before reconnecting the power supply.
- Do not energise circuits with faults that could compromise safety.
- Initial safety checks should include:
  - Ensure capacitors are discharged safely to avoid sparking.
  - No live wires or components are exposed during charging, recovery, or purging.
  - Earth bonding continuity must be verified.

## Repairs to Sealed Components

1. Disconnect the power supply before opening any sealed covers.
2. If power must remain connected during servicing, use a continuously operating leak detector at critical points. Pay special attention to:
  - Preserving original casing protection (e.g. seals, cable fittings).
  - Ensuring that mounting is secure, and seals have not degraded.
  - Using only replacement parts recommended by Kogan.com.

### Note:

The use of silicone sealant may reduce the effectiveness of certain types of leak detection equipment. Intrinsically safe components do not need to be isolated before servicing.

## Repair to Intrinsically Safe Components

- Do not apply permanent inductive or capacitive loads unless safe.
- Only intrinsically safe components may be serviced live in flammable environments.
- Use properly rated testing equipment.
- Replace components only with those specified by Kogan.com to prevent refrigerant ignition.

## Cabling

- Check cables for signs of wear, corrosion, pressure damage, or environmental exposure.
- Consider vibrations from components like fans and compressors.

## Detection of Flammable Refrigerants

- Never use ignition sources to locate refrigerant leaks.
- Do not use halide torches or any leak detector with an open flame.

## **Leak Detection Methods**

- Use electronic leak detectors calibrated in refrigerant-free environments.
- Ensure the detector is non-sparking and suitable for the refrigerant type.
- Set detection sensitivity to 25% of the refrigerant's lower flammable limit (LFL).
- Avoid leak detection fluids with chlorine, which may corrode pipes.
- If a leak is suspected, extinguish any open flames immediately.
- If brazing is necessary, fully recover the refrigerant first and purge with oxygen-free nitrogen (OFN).

## **Removal and Evacuation**

Follow this sequence when opening the refrigerant circuit:

- Recover the refrigerant using certified recovery cylinders.
- Purge the circuit with inert gas (OFN).
- Evacuate the system.
- Repeat the purge/evacuate cycle as needed.

### **Notes:**

- Do not use compressed air or oxygen.
- Vent OFN outside and keep the vacuum pump outlet away from ignition sources.

## **Decommissioning**

- Technicians must be fully familiar with the equipment before decommissioning.
- Recover all refrigerant safely.
- Take oil and refrigerant samples if the refrigerant is to be reclaimed.
- Ensure electrical power is available during the process.
- Checklist:
  - Use mechanical handling if needed for cylinders.
  - Wear proper personal protective equipment.
  - Ensure supervision by a competent person.
  - Comply with standards for recovery equipment and cylinders.
  - Do not overfill cylinders or exceed maximum pressure.
  - Label decommissioned equipment with date and signature.

## **Recovery**

- Only use designated recovery cylinders and equipment for each refrigerant type.
- Cylinders must have relief valves and shut-off valves in good condition.
- Use calibrated weighing scales during recovery.
- Check equipment condition before use and ensure electrical components are sealed.
- Contact **help.Kogan.com** if unsure.
- Do not mix refrigerants.
- Compressors and oils must be evacuated before removal.
- Use only electric heating on the compressor body for oil drainage.

## Inspections Before Test Run

Description	Inspection Method
Electrical Safety Inspection	<ul style="list-style-type: none"><li>• Confirm the power supply voltage is correct.</li><li>• Check for missing or incorrect connections between power, signal, and earth wires.</li><li>• Verify earth and insulation resistance values.</li></ul>
Installation Safety Inspection	<ul style="list-style-type: none"><li>• Ensure proper slope and direction of the drainage pipe.</li><li>• Confirm secure refrigerant pipe joints.</li><li>• Check the stability of both indoor and outdoor units.</li><li>• Make sure valves are fully open.</li><li>• Remove all foreign objects or tools from inside the unit.</li><li>• Confirm that the air inlet grille and panel are fully installed.</li></ul>
Refrigerant Leakage Detection	<ul style="list-style-type: none"><li>• Apply soapy water or foam and check for bubbles.</li><li>• Use an approved leak detector according to its instructions.</li><li>• Each point should be tested for at least 3 minutes.</li><li>• If leaks are found, tighten the nut and retest.</li><li>• Once complete, insulate and tape the indoor unit's pipe connectors.</li></ul>

## Test Run Instructions

1. Turn on the power supply.
2. Press the 'POWER' button on the remote control to start the unit.
3. Press the 'MODE' button to switch between 'Cooling' and 'Heating' modes:
  - For 'Cooling', set to the lowest temperature.
  - For 'Heating', set to the highest temperature.
4. Let the unit run for about 8 minutes in each mode. Confirm:
  - The air temperature changes as expected.
  - Water drains correctly from the hose.
  - Louvres and deflectors move properly (if applicable).
5. Observe the air conditioner for at least 30 minutes.
6. When finished, return to normal settings and press the 'POWER' button to turn off the unit.
7. Instruct the user to:
  - Read the user guide thoroughly before use.
  - Learn how to operate the unit.
  - Follow service and maintenance procedures.
  - Keep accessories in a safe location.

### Note:

If the ambient temperature exceeds the range specified in the operating instructions and the unit cannot run in 'Cooling' or 'Heating' mode, lift the front panel and use the emergency button to operate in 'COOL' or 'HEAT' mode.

## Disposal



This marking indicates that this appliance should not be disposed with other household wastes. To prevent possible harm to the environment or human health from uncontrolled waste disposal, recycle it responsibly to promote the sustainable reuse of material resources.

# Troubleshooting

Problem	Possible Causes
The appliance does not operate.	Power failure/plug pulled out.
	Damaged indoor/outdoor unit fan motor.
	Faulty compressor thermomagnetic circuit breaker.
	Loose connections or plug pulled out.
	Voltage higher or lower than the voltage range.
	A timer to turn the unit on is active.
	Damaged electronic control board.
Unusual odour.	Dirty air filter.
Noise of running water.	Back flow of liquid in the refrigerant circulation.
A fine mist comes from the air outlet.	This occurs when the air in the room becomes very cold, for example in the 'Cooling' or 'Dry' modes.
A strange noise can be heard.	This noise is made by the expansion or contraction of the front panel due to variations in temperature and does not indicate a problem.
Insufficient airflow, either hot or cold.	Unsuitable temperature setting.
	Obstructed air conditioner intakes and outlets.
	Dirty air filter.
	Fan speed set at minimum.
	Other sources of heat in the room.
The appliance does not respond to commands.	No refrigerant.
	Remote control is not close enough to indoor unit.
	The remote control batteries need to be replaced.
The indoor unit display screen is off.	Obstacles between remote control and signal receiver in indoor unit.
	Press the 'DISPLAY' button to turn on the indoor unit display screen.
	Power failure.

Switch off the air conditioner immediately and cut off the power supply in the event of:	Strange noises during operation.
	Faulty electronic control board.
	Faulty fuses or switches.
	Spraying water or objects inside the appliance.
	Overheated cables or plugs.
	Very strong smells coming from the appliance.

## Error Codes

In case of an error, the following error codes will illuminate on the indoor unit display screen. If this occurs, contact [help.Kogan.com](https://www.kogan.com/help) for support.

Error Code	Problem
E1	Indoor room temperature sensor fault.
E2	Indoor pipe temperature sensor fault.
E3	Outdoor pipe temperature sensor fault.
E4	Refrigerant system leakage or fault.
E6	Malfunction of indoor fan motor.
E7	Outdoor ambient temperature sensor fault.
E0	Indoor and outdoor communication fault.
E8	Outdoor discharge temperature sensor fault.
E9	Outdoor IPM module fault.
EA	Outdoor current detect fault.
EE	Outdoor PCB EEPROM fault.
EF	Outdoor fan motor fault.
EH	Outdoor suction temperature sensor fault.





### **Need more information?**

We hope that this user guide has given you the assistance needed for a simple set-up.

For the most up-to-date guide for your product, as well as any additional assistance you may require, head online to [help.Kogan.com](https://help.kogan.com).

**kogan**  
.com